

# Kitchen Safety

Stay fire safe in the kitchen!

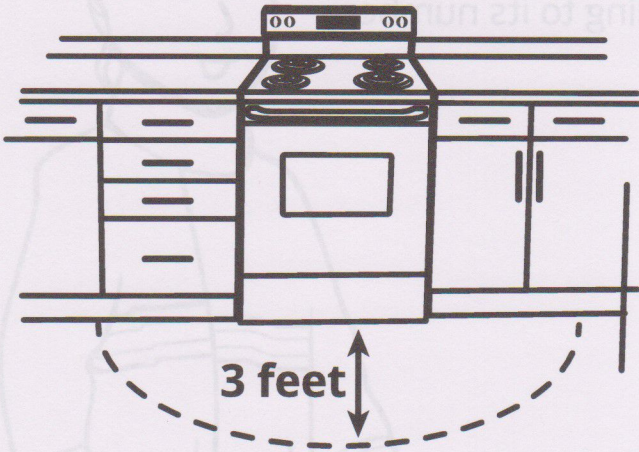
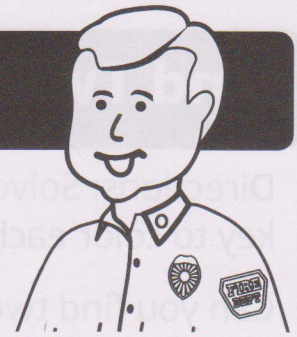

- Stay 3 feet away from the stove or oven.

- Don't put anything that can burn on the stove.

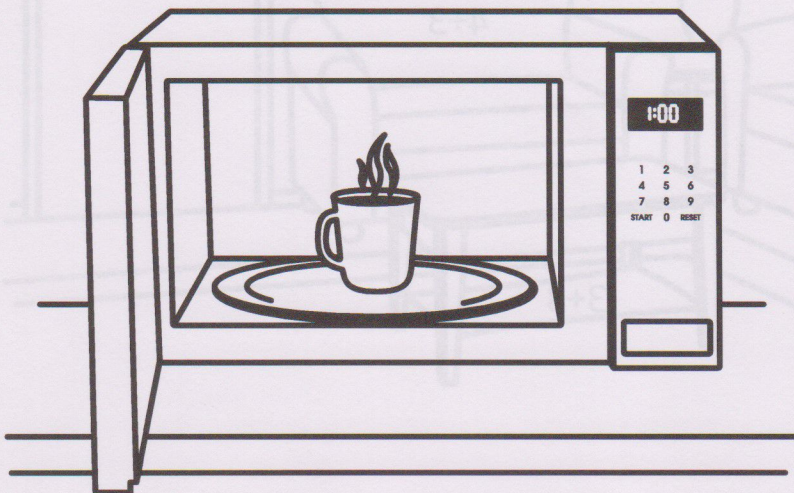

- If you are allowed to use the microwave, remember that the microwave and food inside can get very hot.
- Let the food cool in the microwave after it cooks.
- Remove food slowly so it doesn't spill on you.